

THIS DOCUMENT CONTAINS PROPRIETARY INFORMATION WHICH IS THE PROPERTY OF QSC, LLC. THAT MAY NOT BE DISCLOSED, REPRODUCED OR USED WITHOUT EXPRESS WRITTEN CONSENT FROM QSC, LLC.

REVISIONS			
REV	DESCRIPTION	BY	DATE
A	RELEASE FOR SALES AND MARKETING	ES	19-DEC-17

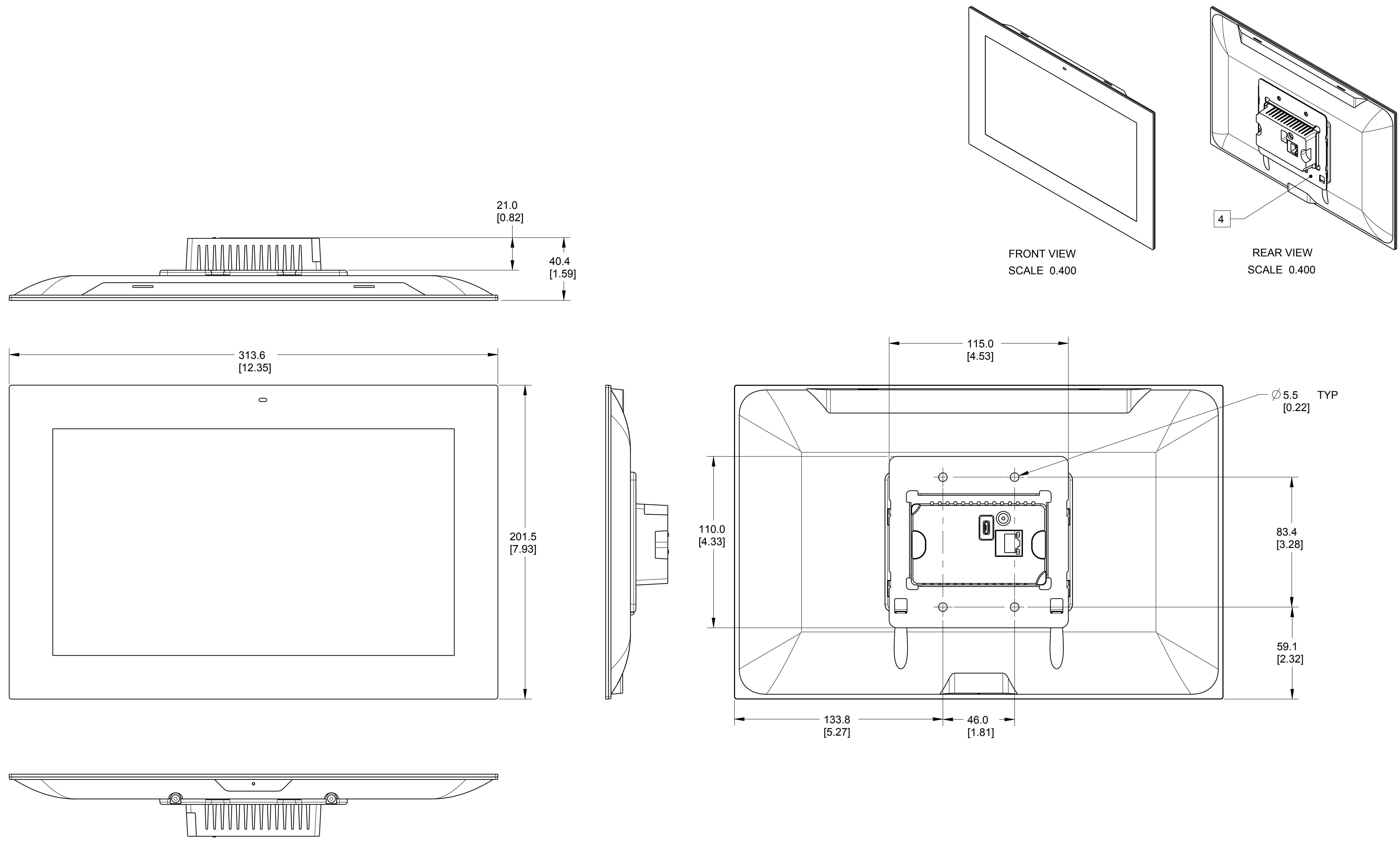

- 4 INSTALL MOUNTING FLANGE TO ELECTRICAL BOX FIRST, THEN ATTACH TOUCH PANEL TO MOUNTING FLANGE.
- 3. DIMENSIONS ARE IN MILLIMETERS [INCH].
- 2. TOLERANCES (MM): X \pm 3, ANGLES: \pm 1°.
- 1. NET WEIGHT APPROX. 0.91 KG [2.0 LBS].

NOTES: UNLESS OTHERWISE SPECIFIED.

UNLESS OTHERWISE SPECIFIED DIMENSIONS IN MILLIMETERS (IN) TOLERANCES ARE: DECIMALS DECIMALS ANGLES X: ± 5(0.2) XX: ± 25(0.9) ± 1/2 DEBURR EDGES .25 (0.01) R MAX	DESIGNER	QSC, LLC	
	ENGINEER	1675 MACARTHUR BOULEVARD COSTA MESA, CA 92626	
	TECHNICAL DIRECTOR	PROCESSOR, TSC-116W-G2-BK, Q-SYS	
	MANUFACTURING ENGINEER	11.6" IN-WALL TOUCH PANEL	
MATERIAL	T. MORGAN	SIZE	REV
FINISH	DRAWING INFO: FG-117050-2D.A.0	D 00PW4	A
	MODEL INFO: FG-117050-3D.A.0	DRAWING NO. FG-117050-2D	1 OF 1
	SCALE: 0.750	DO NOT SCALE DRAWING	